

EtherCAT



## ECAT-2091S

EtherCAT Single Axis Stepper Motor Controller/Driver

### Features

- 1 x Stepper motor (2-phase bipolar stepper motor)
- Drive capability up to 1.5 A/phase coil current (with proper cooling and airflow up to 2.0 A/phase)
- Voltage range of the motor: 6 to 46 VDC
- 1 x 5V power supply for encoder. Limitation: the output current should not exceed 150mA
- 1 x Encoder interfaces (A, B, Z), differential
- 2 x Digital input: Reference switch input, latch input
- 1 x Digital output
- Highest resolution: 256 microsteps per full step
- Automatic current reduction to reduce heat when motor is not moving
- Over-temperature protection
- Optically isolated I/O
- LED indicators for I/O, EtherCAT and motion status
- EtherCAT:
  - 2 x RJ-45 bus interface
  - Distance between stations up to 100 m (100BASE-TX)
  - Support daisy chain connection
  - EtherCAT conformance test tool verified
  - Supports Free-Run, SM synchron and Distributed Clock (DC) operation modes
- Removable terminal block connector



### Introduction

The ECAT-2091S stepper motor controller is a cost-effective, two-phase bipolar stepper driver. A motor voltage range between 6 and 46 VDC and a peak motor coil current of 1.5 A/phase without cooling is being supported. When operating in a properly ventilated environment (cooling fan) the ECAT-2091S can drive the motor at a current level of up to 2.0 A/phase. The maximum running motor current, microstep resolution and other motion parameters are software selectable.

The ECAT-2091S is a standard EtherCAT slave and an EtherCAT master is required to operate the device. The ECAT-2091S supports three operation modes: Free-Run, SM synchron and Distributed Clock (DC).

Two-phase bipolar stepper motors can be directly connected to the ECAT-2091S device. The device is designed to operate in an open loop. Configuration and motion control has to be done by the EtherCAT master and the application program. The coil current and step control is done by a stepper motor driver IC. An integrated ramp generator automatically calculates the acceleration and deceleration distance. In position mode the controller drives the motor to the target position and in velocity mode accelerates the motor to the target velocity. A minimum set of configuration data consists of acceleration, deceleration and maximum motion velocity. After receiving the target position the motor driver starts controlling the motion movement. All motion parameters can be changed on the fly.

The ECAT-2091S has a 32 bit high frequency encoder counter which counts the input signal of an external incremental encoder. The encoder can for example be used for homing purposes and for consistency checks.

High resolution of up to 256 microsteps per full step is supported for ensuring smooth and precise motor operation.

Two digital input channels are provided. The digital inputs can be set to act as a simple DI, as a left and right hardware limit switch which automatically stops the motor when activated, or a latch trigger for latching the current motor and encoder position.

The module must be supplied by two power sources. A motor supply and a 24 VDC control supply.

### Applications



## Hardware Specifications

<b>Motor Outputs</b>		
No. of Axes	1 × Stepper motor, 2 phases	
Output Current	peak 1.5 A/phase (with proper airflow up to 2.0 A/phase)	
Voltage Range of the Motor Output	6 to 46 VDC	
Current Controller Frequency	24.5 kHz	
Maximum Step Frequency	8.388 MHz	
Microsteps Per Step	256, 128, 64, 32, 16, 8, 4, 2	
<b>Encoder</b>		
No. of Axes	1, differential	
Max. Encoder Pulse Frequency	4 MHz	
Power Supply	5V (Restriction: the output current should not exceed 150 mA)	
<b>Digital Inputs</b>		
Channels	2	
Wet Contact	ON Voltage Level	+19 to 30 VDC
	OFF Voltage Level	+11 Vdc MAX
Photo-isolation	3750 VDC	
<b>Digital Output</b>		
Number of Digital Outputs	1	
Output Type	Open collector	
Load Voltage	+5 to 30 VDC	
Max. Load Current	100 mA	
Isolation Voltage	3750 Vdc	
<b>LED Indicators</b>		
Diagnostic LED	Power, EtherCAT status, Digital IO, driving, temperature warning, over-temperature error, phase A and B under-voltage	
<b>Communication Interface</b>		
Connector	2 × RJ-45	
Protocol	EtherCAT	
Distance Between Stations	Max. 100 m (100BASE-TX)	
Data Transfer Medium	Ethernet/EtherCAT Cable (Min. CAT 5), Shielded	
<b>Power</b>		
Input Voltage Range	20 V ~ 30 VDC	
<b>EMS Protection</b>		
ESD (IEC 61000-4-2)	4 KV Contact for each channel	
EFT (IEC 61000-4-4)	Signal: 1 KV Class A; Power: 1 KV Class A	
Surge (IEC 61000-4-5)	1 KV Class A	
<b>Mechanical</b>		
Installation	DIN-rail mounting or wall mounting	
Dimensions (W × L × H)	DIN-rail mounting	33 mm × 120 mm × 116 mm
	Wall mounting	33 mm × 159 mm × 110 mm
Casing	Metal	
<b>Environment</b>		
Operating Temperature	-25 ~ +40°C	
Storage Temperature	-30 ~ +80°C	
Relative Humidity	10 ~ 90% RH, Non-condensing	

## Pin Assignments

Name	Signal	Signal Description
OA1	Output	Motor winding A1
OA2	Output	Motor winding A2
OB1	Output	Motor winding B1
OB2	Output	Motor winding B2
LL	Input	Left limit switch for motor
RL	Input	Right limit switch for motor
GDO0	Output	General purpose digital output channel 0
DI.COM		Common DI supply: 0V or +10 to +24 VDC (0V for current sinking)
+VS		+24 VDC
GND		Ground 0V



Name	Signal	Signal Description
A+	Input	Encoder input A+
A-	Input	Encoder input A-
B+	Input	Encoder input B+
B-	Input	Encoder input B-
C+	Input	Encoder input C+
C-	Input	Encoder input C-
+5V	Output	Power supply to encoder Limitation: • The output current should not exceed 150mA • Only one encoder should be connected
+VM	Input	Motor power supply +6 to 46 VDC (from positive power contact)
+VS		+24 VDC
GND		Ground 0V



Name	Signal
<b>F.G</b>	Frame ground
<b>GND</b>	Power supply: Ground 0V (from negative power contact)
<b>+Vs</b>	Power supply: +24 VDC (from positive power contact)
<b>IN</b>	EtherCAT signal input
<b>OUT</b>	EtherCAT signal input

## Dimensions (Units: mm)

### DIN-rail mounting

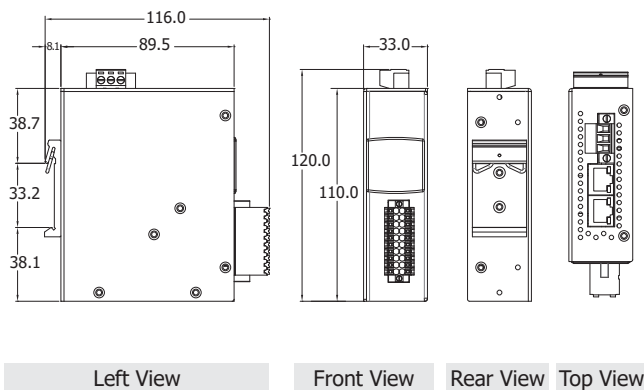

### Wall mounting

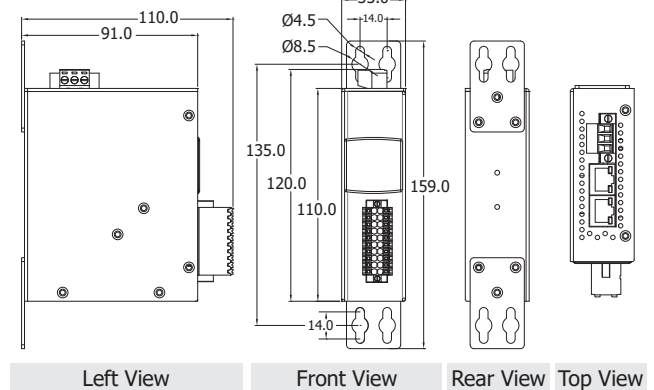

## Wire Connections

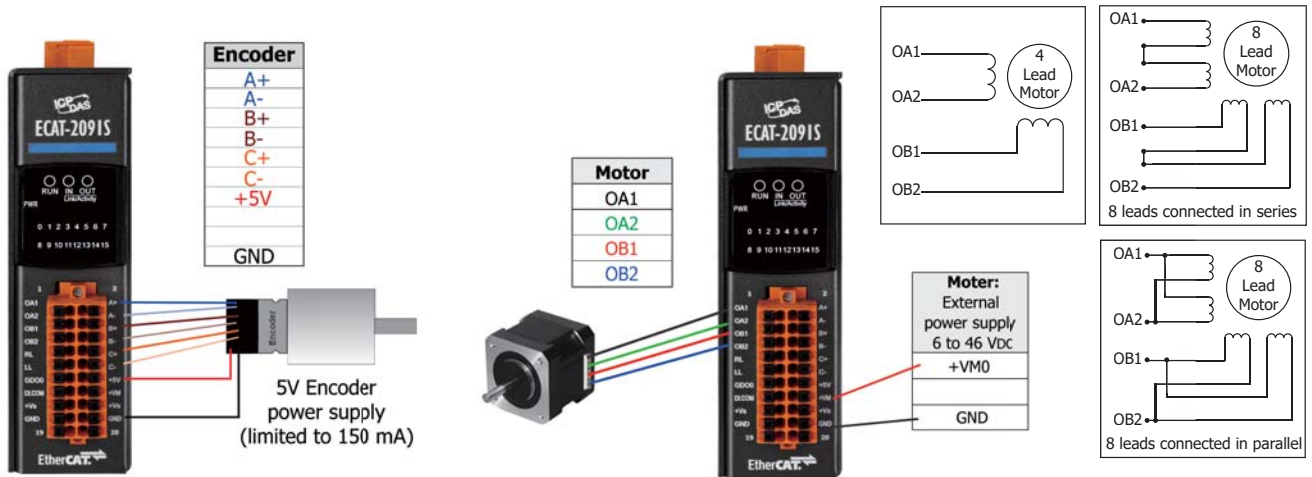

## Digital Input Channel

Digital Input	Readback as 1	Readback as 0
Sink	+10 ~ +24 VDC 	OPEN or <4 VDC 
	+10 ~ +24 VDC 	OPEN or <4 VDC 
Source	+10 ~ +24 VDC 	OPEN or <4 VDC 
	+10 ~ +24 VDC 	OPEN or <4 VDC 

## Digital Output Channel

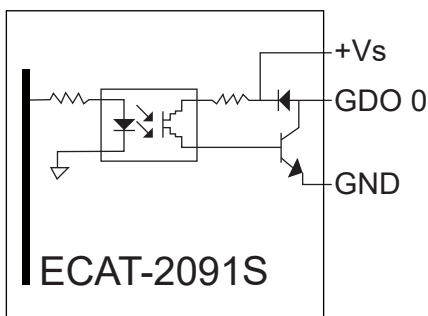

Output Type	ON State Readback as 1	OFF State Readback as 0
Drive Relay	 +Vs GDO 0 GND	 +Vs GDO 0 GND
Resistance Load	 +Vs GDO 0 GND	 +Vs GDO 0 GND

## Ordering Information

<b>ECAT-2091S CR</b>	EtherCAT single axis stepper motor controller/driver (Metal Case) (RoHS) Includes 4SIN1K0000067 Wall mount (W: 28 mm)
----------------------	--