

# SG-3383 Isolated DC Current 1-channel Input to 3-channel Output Module User's Manual

Rev1.00

## Introduction

The SG-3383 is a 1-channel current input to 3-channel current output signal conditioning module that provides 3000 V<sub>DC</sub> 3-way isolation for input, output and power, together with 8 kV ESD Protection as well as 3000 V<sub>DC</sub> intra-module isolation.

The SG-3383 includes an LED display that can be used to indicate whether the module is functioning correctly, and also includes VRs (Zero, Span) that can be used to calibrate the output range accuracy. The input bandwidth of the SG-3383 is typically 2.5 kHz.

The SG-3383 can be easily mounted on a standard DIN Rail and can operate in environments where there is a wide temperature range.

## Specifications

### **Current Input:**

- ◆ Unipolar: +4 ~ +20 mA
- ◆ Input Impedance: 124 Ω
- ◆ Input Bandwidth: 2.5 kHz (typical)

### **Current Output:**

- ◆ Current: +4 ~ +20 mA
- ◆ Current Load Resistor: 0 ~ 500 Ω

### **General:**

- ◆ 3-way Isolation: 3000 V<sub>DC</sub>
- ◆ Accuracy: ±0.1% of FSR (typical)
- ◆ Operation Temperature Range: -25°C to +75°C
- ◆ Storage Temperature Range: -30°C to +85°C
- ◆ Operation Bandwidth: 2.5 kHz

### **Supply Voltage:**

- ◆ Input Range: +10 ~ +30 V<sub>DC</sub>  
@ 24 V<sub>DC</sub> (Typical)
- ◆ Consumption: 2.5 W

For more details, please visit at

[http://www.icpdas.com/root/product/solutions/signal\\_conditioning\\_modules/sg-3000/sg-3383.html](http://www.icpdas.com/root/product/solutions/signal_conditioning_modules/sg-3000/sg-3383.html)

## Pin Assignments/Wiring

- ◆ The terminal wiring for the SG-3383 is shown below
- ◆ Power input, current input and current output can be connected
- ◆ The SG-3383 uses a power input range of +10 ~ +30 V<sub>DC</sub>

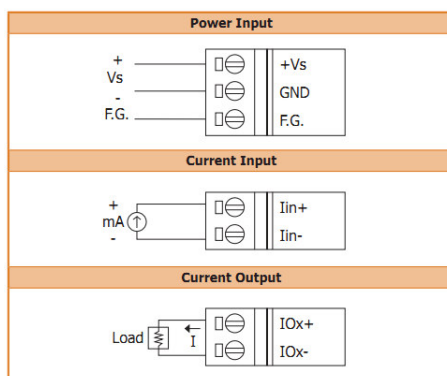
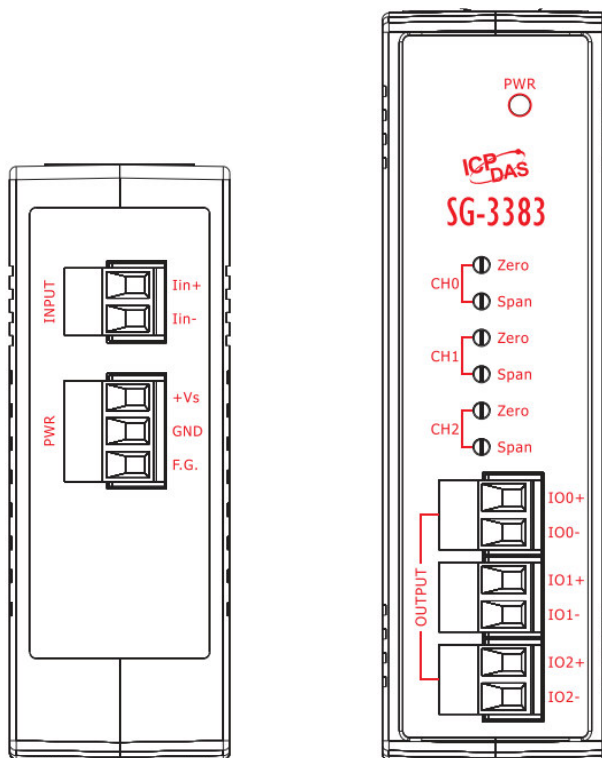

# Configuration

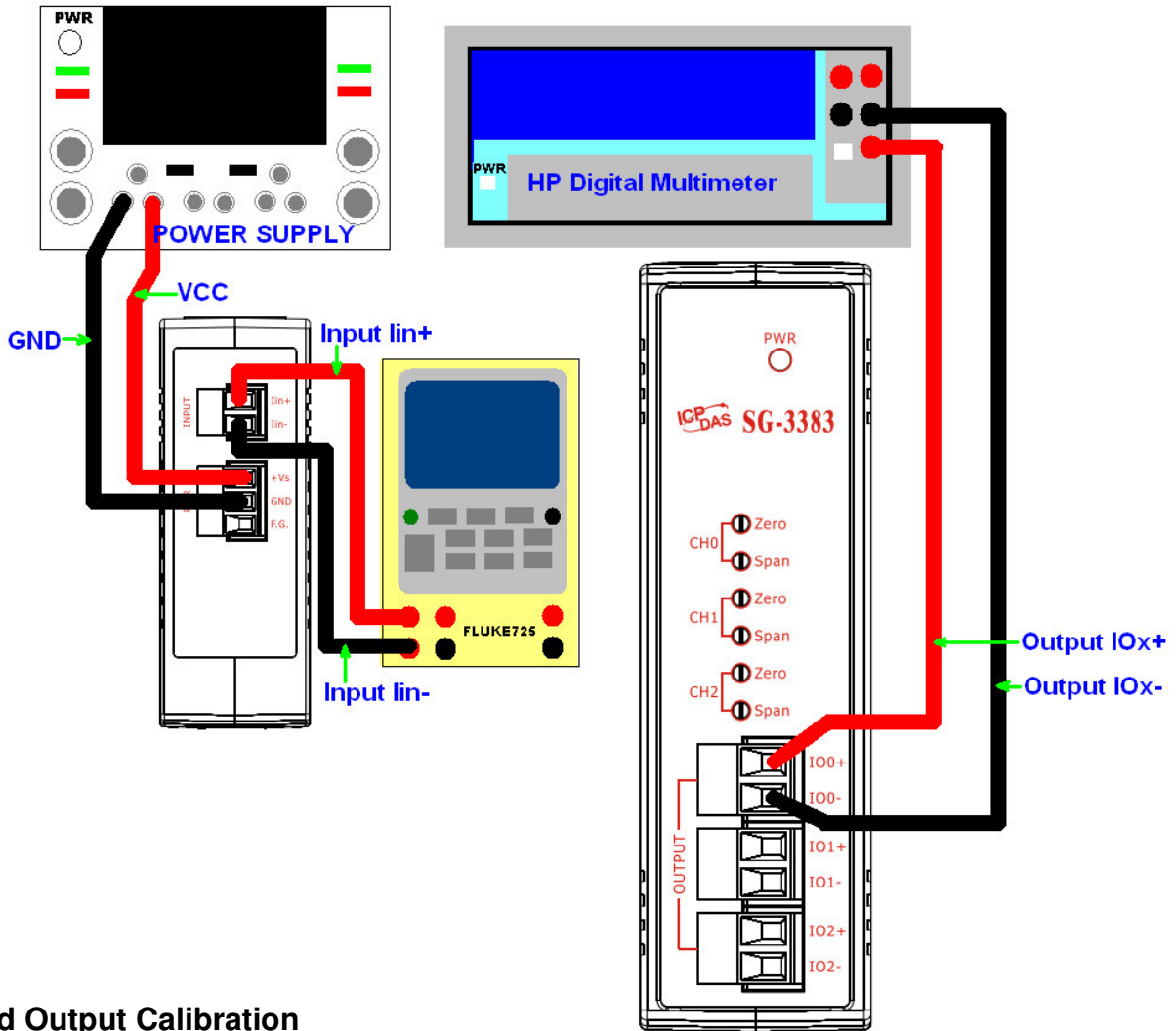

## Input and Output Calibration

- \*\* Define the following variables for calibration use \*\*
- Source current input +4 mA = output reading +4 mA
  - Source current input +20 mA = output reading +20 mA

- ◆ 1. Connect a +4 mA source current to the INPUT pin the SG-3383, and read the output for the 4 mA signal on the multimeter.
- ◆ 2. Connect a +20 mA source current to the INPUT pin the SG-3383, and read the output for the 20 mA signal on the multimeter.
- ◆ 3. Adjust the ZERO variable resistor the SG-3383 and repeat Steps 1 and 2 until the following condition are met.

(Source current for the +4 mA input signal = output value read for the 20 mA signal)--eq1

- ◆ 4. Adjust the SPAN variable resistor the SG-3383 and repeat Steps 1 and 2 until the following conditions are met.

(Source current for the +4 mA input signal = output value read for the +4 mA signal)---eq2  
 (Source current for the +20 mA input signal = output value read for the +20 mA signal)---eq3

- ◆ 5. If the readings fail to meet the conditions described in eq2 and eq3, repeat Steps 3 and 4 for channels 0, 1 and 2 until the conditions specified in Step 4 are successfully met.

## Block Diagram

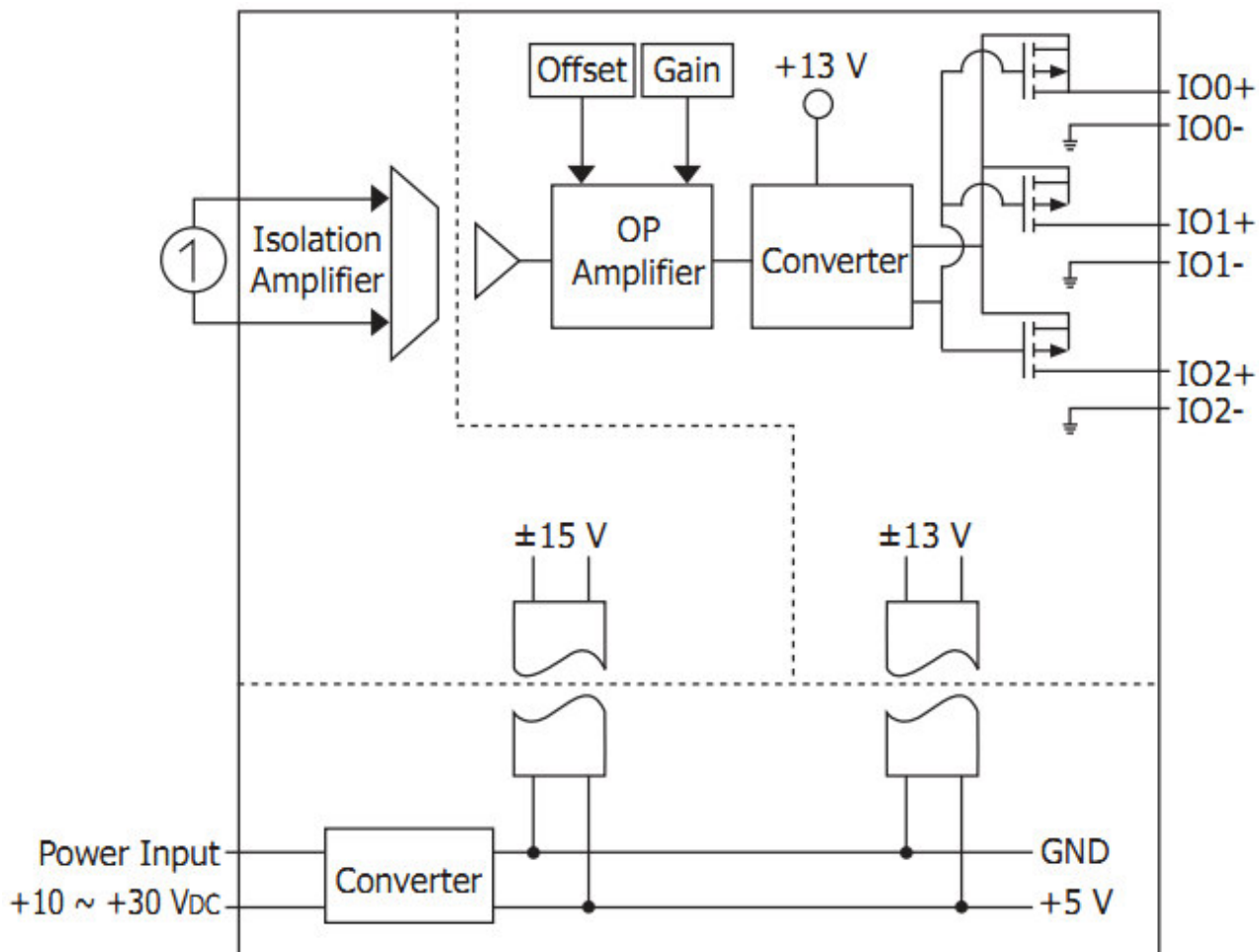

## Dimensions (Units: mm)

