



EMC Test Report

Product Type : ICP DAS with Converter
Applicant : ICP DAS CO., LTD.
Address : No. 111, Kuangfu N. Rd., Hukon Shiang, Hsinchu, Taiwan 303, R.O.C
Trade Name : ICP DAS
Model Number : TP-4100
Test Specification : EN 55022: 2010 +AC:2011 / Class A
EN 55024: 2010
EN 61000-3-2: 2006 +A1:2009 + A2: 2009 / Class A
EN 61000-3-3: 2008
Receive Date : Feb. 20, 2013
Test Period : Feb. 26, 2013 ~ Mar. 04, 2013
Issue Date : Mar. 12, 2013

Issue by

A Test Lab Techno Corp.
No. 140-1, Changan Street, Bade City,
Taoyuan County 334, Taiwan R.O.C.
Tel : +886-3-2710188 / Fax : +886-3-2710190



Taiwan Accreditation Foundation accreditation number: 1330

Note: This report shall not be reproduced except in full, without the written approval of A Test Lab Techno Corp. This document may be altered or revised by A Test Lab Techno Corp. personnel only, and shall be noted in the revision section of the document. The client should not use it to claim product endorsement by TAF, or any government agencies. The test results in the report only apply to the tested sample.

Verification of Compliance

Issued Date: 2013/03/12

Product Type : ICP DAS with Converter
Applicant : ICP DAS CO., LTD.
Address : No. 111, Kuangfu N. Rd., Hukon Shiang, Hsinchu, Taiwan 303,
R.O.C
Trade Name : ICP DAS
Model Number : TP-4100
EUT Rated Voltage : 230 Vac / 50 Hz
Test Voltage : 230 Vac / 50 Hz
Applicable : EN 55022:2010 +AC:2011 / Class A
Standard : EN 55024:2010
EN 61000-3-2:2006+A1:2009+A2:2009 / Class A
EN 61000-3-3:2008
Test Result : Complied

Performing Lab. : A Test Lab Techno Corp.

No. 140-1, Changan Street, Bade City,
Taoyuan County 334, Taiwan R.O.C.

Tel : +886-3-2710188 / Fax : +886-3-2710190

Taiwan Accreditation Foundation accreditation number: 1330

<http://www.atl-lab.com.tw/e-index.htm>



The above equipment has been tested by A Test Lab Techno Corp., and found compliance with the requirements set forth in the Electromagnetic Compatibility Directive 2004/108/EC and technical standards mentioned above. The results of testing in this report apply only to the product/system, which was tested. Other similar equipment will not necessarily produce the same results due to production tolerance and measurement uncertainties.

Approved By



(Manager)

(Murphy Wang)

Reviewed By



(Testing Engineer)

(Frank Lin)

Feature of Equipment under Test :

The model listed below is series model to TP-4100.

Main	Software	Diversity	Mode 1
EIP-2042	---	Isolated 16-ch DO EtherNet/IP Module (RoHS)	V
EIP-2051	---	Isolated 16-ch DI EtherNet/IP Module (RoHS)	V
EIP-2055	---	Isolated 8-ch DI & 8-ch DO EtherNet/IP I/O Module	V
EIP-2060	---	Isolated 6-ch DI & 6 Relay Output EtherNet/IP I/O Module	V
NS-208PSE-IP67	---	Industrial 8-port unmanaged IP67 Ethernet switch with PoE Includes IP67 RJ-45 Plug x 8, IP67 Power Plug x 1, Cap with Tether x 8 (RoHS)	V
USB-2514	---	USB to 4-Port RS-232 Converter(RoHS)	V
tET-PD6	---	Ethernet module with 6-ch DI (RoHS)	V
tET-P6	---	Tiny Ethernet module with 6-ch DI (RoHS)	V
tM-7520U	---	Isolated RS-232 to RS-485 Converter (RoHS)	V
M-7068D	---	M-7068 with LED Display (RoHS)	V
M-7068	---	4-channel Form A Signal Relay Output and 4-channel Form C Signal Relay Output Module (Gray Cover) (RoHS)	
M-7069D	---	M-7069 with LED Display (RoHS)	V
M-7069	---	4-channel Form A Power Relay Output and 4-channel Form C Power Relay Output Module (Gray Cover) (RoHS)	
TP-4100	---	10.4" (800 x 600) resistive touch panel monitor with RS-232 or USB interface	V
TPM-4100	---	TP-4100 with Aluminum Casing	

3.3. Configuration of Test System

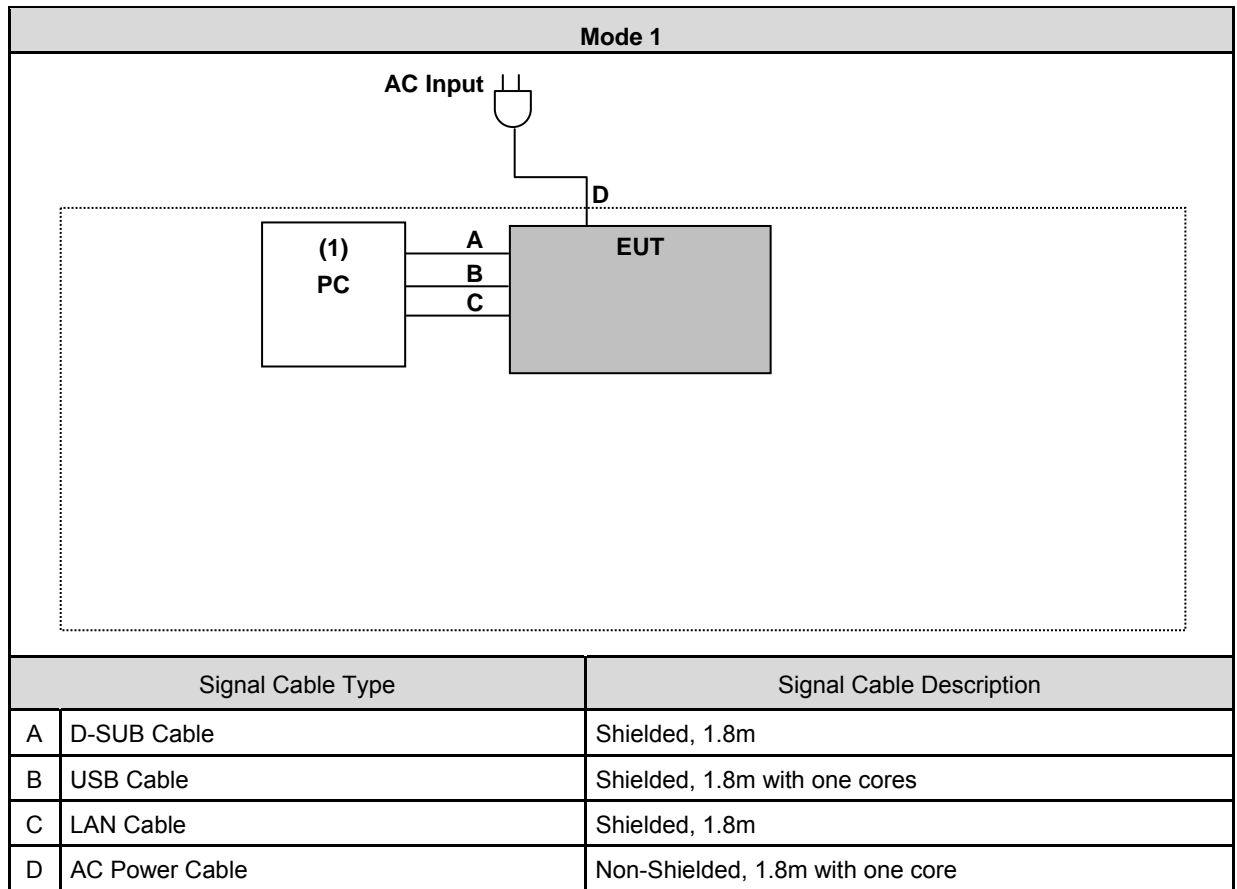

Devices Description					
	Product	Manufacturer	Model Number	Serial Number	Power Cord
(1)	PC	SYNNEX	MPD-K6XV3	N/A	Non-Shielded, 1.8m
※ PC Keypart information					
	Main	Software	Diversity		
(1)-1	PISO-CAN800U-D	---	8-Port Isolated Protection Universal PCI CAN Communication Board		
(1)-2	PCI-D64HU	---	40 MB/s High-speed 32-CH DI and 32-CH DO Universal PCI DIO Card (RoHS)		
(1)-3	PISO-CAN100U-D	---	1-Port Isolated Protection Universal PCI CAN Communication Board with 9-pin D-sub connector (RoHS)		
(1)-4	PISO-CAN100U-T	---	1-Port Isolated Protection Universal PCI CAN Communication Board with 5-pin Screw Terminal Connector(RoHS)		